

MaxiFil Clean

EN – Operating Manual

1	General	- 7 -
1.1	Introduction.....	- 7 -
1.2	References to copyright and industrial property rights.....	- 7 -
1.3	Notes for the operating company	- 7 -
2	Safety.....	- 9 -
2.1	General information	- 9 -
2.2	Information on signs and symbols.....	- 9 -
2.3	Markings/signs to be affixed by the operating company	- 10 -
2.4	Safety instructions for operating staff	- 10 -
2.5	Safety instructions for maintenance/troubleshooting.....	- 11 -
2.6	Notes regarding special types of hazard	- 11 -
3	Product information.....	- 15 -
3.1	Functional description.....	- 15 -
3.2	Distinguishing feature – W3 certified	- 17 -
3.3	Intended use.....	- 17 -
3.4	Ambient conditions	- 18 -
3.5	General requirements in accordance with DIN EN ISO 21904	- 20 -
3.6	Reasonably foreseeable misuse.....	- 20 -
3.7	Markings and signs on the product.....	- 21 -
3.8	Residual Risk	- 21 -
4	Transport and Storage	- 23 -
4.1	Transport	- 23 -
4.2	Storage	- 23 -
4.3	Safety instructions for transporting the product.....	- 24 -
5	Assembly.....	- 27 -
6	Use	- 30 -
6.1	Qualification of the operating personnel	- 30 -
6.2	Operating elements.....	- 30 -
6.2.1	Menu – Queries and settings	- 32 -
6.2.2	Activation codes	- 33 -
6.2.3	Displaying the product ID.....	- 33 -
6.2.4	Automatic start/stop/external on/off.....	- 34 -
6.2.5	Warning – Insufficient extraction capacity	- 34 -

6.2.6	Cleaning the filter cartridge.....	- 34 -
6.3	Positioning the extraction hood.....	- 35 -
6.4	Commissioning.....	- 36 -
7	Maintenance.....	- 37 -
7.1	Care.....	- 37 -
7.2	Maintenance.....	- 38 -
7.2.1	Special Notes on Laser Welding.....	- 38 -
7.2.2	Changing the filter – Safety instructions.....	- 38 -
7.2.3	Changing filters.....	- 40 -
7.2.4	Checking the compressed air container with compressed air safety valve.....	- 44 -
7.2.5	Checking the compressed air safety valve.....	- 44 -
7.3	Troubleshooting.....	- 46 -
7.4	Troubleshooting - Error Codes.....	- 46 -
7.5	Troubleshooting Warnings.....	- 48 -
7.6	Emergency measures.....	- 48 -
8	Disposal.....	- 49 -
8.1	Plastics.....	- 49 -
8.2	Metals.....	- 49 -
8.3	Filter elements.....	- 49 -
9	Annex.....	- 50 -
9.1	EU Declaration of Conformity.....	- 50 -
9.2	UKCA Declaration of Conformity.....	- 51 -
9.3	Technical data.....	- 52 -
9.4	Dimensions sheet.....	- 53 -
9.5	Spare parts.....	- 54 -
9.6	Accessories.....	- 54 -

1 General

1.1 Introduction

This manual is an essential aid for the proper and safe operation of the product.

These operating instructions contain important information to ensure safe, proper and efficient operation of the product. Observing these instructions helps avoiding danger, reducing repair costs and downtimes and increasing the reliability and service life of the product. The operating instructions must be kept available at all times and have to be read and applied by every person who is assigned to work on or with the product.

These include amongst others:

- the operation and troubleshooting during operation
- the maintenance (care, maintenance, repair)
- the transport
- the assembly
- the disposal

Technical modifications and errors expected.

1.2 References to copyright and industrial property rights

These operating instructions are to be kept confidential and made accessible only to authorised persons. Disclosure to third parties is only permitted with the prior written consent of the manufacturer KEMPER GmbH.

All documents are protected under the Copyright Act. Any form of disclosure, reproduction, or partial use, as well as the communication of its content, is prohibited without express written permission.

Violations will be prosecuted under criminal law and will incur liability for any resulting damages.

Industrial property rights such as patents, trademarks, or designs are exclusively held by the manufacturer.

1.3 Notes for the operating company

The operating instructions are an essential part of the product. The operating company must ensure that the operating personnel is aware of the contents of this manual.

Based on national regulations for accident prevention and environmental protection, the operating instructions are to be supplemented by the operating company's own operating instructions, including information on regulatory and reporting requirements to meet specific operating requirements, such as work organisation, work flow and staff employed. In

addition to the operating instructions and the relevant obligatory regulations for accident prevention applicable in the country of use, it is also imperative to comply with the recognised technical rules for safe and professional handling.

Without prior consent from the manufacturer, the operating company may not carry out any changes, conversions or additions to the product which may impair safety. Spare parts used must comply with the manufacturer's specified technical requirements. This is always the case with original replacement parts.

Only use trained and instructed staff for the operation, maintenance, repair and transport of the product. Clearly define for staff who is responsible for operation, maintenance and transport.

2 Safety

2.1 General information

The product is designed and built according to state-of-the-art technology and the recognised safety rules and regulations. When operating the product, technical hazards for the operator or impairment of the product as well as other property may occur, if:

- it is not operated by trained or instructed personnel
- it is not used for the purpose intended and/or
- it is improperly maintained

2.2 Information on signs and symbols

▲ DANGER

This symbol in conjunction with the signal word "Danger" indicates imminent danger. Non-adherence of the safety note leads to death or serious injuries.

▲ WARNING

The symbol in conjunction with the signal word "Warning" indicates a potentially dangerous situation. Non-adherence to the safety notice may lead to death or serious injuries.

▲ CAUTION

The symbol in conjunction with the signal word "Caution" indicates a potentially dangerous situation. Non-adherence of the safety note may lead to slight or negligible injuries.

May also be used for warnings against property damage.

NOTE

The general information is simple additional information which does not warn about personal injury or property damage.

1. Enumerations of action steps are marked as numbers with a dot, where the order is important.
- Bullet points indicate lists of parts in a legend or instructions for which the sequence is unimportant

2.3 Markings/signs to be affixed by the operating company

The operating company is obliged to post further markings and signs on the product and the surrounding area if necessary.

Such markings and signs might be related, for example, to the requirement for wearing personal protective equipment.

2.4 Safety instructions for operating staff

Before use, the operator of the product must be instructed through information, instructions and training on the handling of the product and the materials and aids to be used.

The product system may only be used in technically perfect condition, for its intended purpose, in full awareness of the safety aspects and potential dangers and in accordance with these instructions. All errors, especially those that may affect safety, must be removed immediately.

Every person who is charged with commissioning, operation or maintenance must have fully read and understood these operating instructions. This specifically applies to staff who only operate the product occasionally.

The operating instructions must always be within reach of the product.

We accept no liability for any damages or injuries caused by failure to observe these operating instructions.

The relevant accident prevention regulations and other generally recognised safety and occupational health regulations must be observed.

The responsibilities for the various activities included in maintenance and repair must be clearly defined and adhered to. Only then will human error - especially in dangerous situations - be avoided.

The operating company is to enforce wearing of personal protective equipment by operating and maintenance staff. These include in particular safety shoes, safety glasses and gloves.

Do not wear loose, long hair, loose clothing or jewellery. In theory, there is a risk of getting caught on something, or being pulled in or dragged along by moving parts.

If there are any safety-related changes to the product, immediately halt the process, secure it and report the occurrence to the relevant authority/person!

Work on the product may only be carried out by reliable, trained staff. Observe the minimum legal age.

Staff who require training, teaching or instructing or staff who undergo a general apprenticeship may only operate the product under the supervision of an experienced member of staff.

2.5 Safety instructions for maintenance/troubleshooting

Service and maintenance doors must be freely accessible at all times.

Setting up, maintenance and repair work and troubleshooting must only be performed when the product is switched off.

Always tighten bolt connections that have been loosened during repair work. If specified, tighten the relevant bolts with a torque wrench.

In particular, protect connections and screw connections from dirt or care products at the beginning of maintenance/repair/care

The time frames for periodic testing/inspections stipulated or specified in the operating instructions must be observed.

Before disassembling, mark the parts that belong together.

2.6 Notes regarding special types of hazard

⚠ DANGER

Danger of electric shock!

Any work on the electrical equipment of the product must only be performed by a qualified electrician or by operating personnel under the direction and supervision of a qualified electrician in accordance with electronic regulations.

Before opening the product, pull the plug, if available, and secure it against accidental switch-on.

For faults with the product's electrical energy supply, immediately switch the product off at the on/off switch and if available, also pull the plug.

Use only original fuses with the prescribed amperage.

Electrical components, on which inspection, maintenance and repair work must be carried out, must be disconnected from the power supply. Secure equipment that has been used for disconnection against unintentional or automatic reconnection. Firstly check that no voltage is present in activated, electrical components, then isolate adjacent components under voltage. When making repairs, ensure that constructive characteristics are not altered in a way that reduces safety.

Check cables regularly for damage and replace if necessary.

**⚠ WARNING****Electric shock if earthing is missing!**

If the protective earth connection of devices is missing or incorrectly executed, high voltages may be present on exposed parts or housing parts which, if touched, can lead to serious injury or death.

⚠ WARNING**Electric shock if an unsuitable power supply is connected!**

The connection of an unsuitable power supply can cause parts that can be touched to be under dangerous voltage. Contact with dangerous voltage can lead to serious or fatal injury.

For electrical connection data, see the name plate of the product

Power supply

The product is designed for the mains voltage indicated on the name plate. If mains cables or mains plugs are not fitted to the product, they must be fitted in accordance with national standards.

⚠ CAUTION**Insufficiently dimensioned electrical installation can lead to serious damage to property.**

The mains supply line and its fuse protection must be designed in accordance with the existing power supply. Observe the technical data on the name plate.

The mains fuse should be equipped with at least a **category C** circuit breaker.

⚠ WARNING

Danger from toppling over during transport!

The product may tilt and topple over when moved. People can be injured due to the high dead weight.

- Before moving, release the brakes on the castors.
- Move and set down the product only on flat, smooth floor coverings.
- Only move the product with the push handle.
- Do not use the push handle to lift the product.
- Do not sit or climb on the product.
- Before moving; if present, fold in suction arm / wind up or dismantle suction hoses

⚠ WARNING**Health hazards caused by welding fume particles**

Do not inhale welding dust / smoke! Serious injury to the lungs and respiratory tract is possible!

Sweat smoke contains substances that can cause cancer!

Skin contact with cutting and welding fumes etc. can cause skin irritation in sensitive persons!

Repair and maintenance work on the product may only be carried out by trained and authorised personnel while complying with the safety rules and the applicable accident prevention regulations.

To avoid contact with and inhalation of the dust particles, wear disposable overalls, protective goggles, gloves and a suitable Class FFP2 respiratory protection filter mask in accordance with EN 149.

The release of hazardous dust particles during repair and maintenance is to be avoided to ensure that persons not charged with the task are not affected.

⚠ WARNING

Work on the compressed air vessel and on the compressed air lines and components may only be performed by persons with expertise in pneumatics.

The pneumatic system must be isolated and depressurised prior to the performance of maintenance and repair work on the external compressed air supply.

▲ CAUTION**Health hazard due to noise!**

The product can produce noise, please refer to information in the technical data. In connection with other machines and/or local conditions, a higher noise level can occur at the operation site of the product. In this case, the operating company is obliged to provide the operating personnel with the appropriate protective equipment.

3 Product information

3.1 Functional description

The product is a compact welding fumes filter device that extracts welding fumes at the point where they are produced and extracts them with a filter efficiency of more than 99%.

The product is equipped with a flexible extraction arm whose extraction hood is easy to move and is self-supporting in any position.

The extracted air is cleaned using a 2-stage filter method and then fed back into the workspace.

The particles separated by the filter cartridge are repelled by an automatic compressed air pulse system by means of a rotary separator. The repelled particles fall into a dust collection container that then can be removed for disposal.

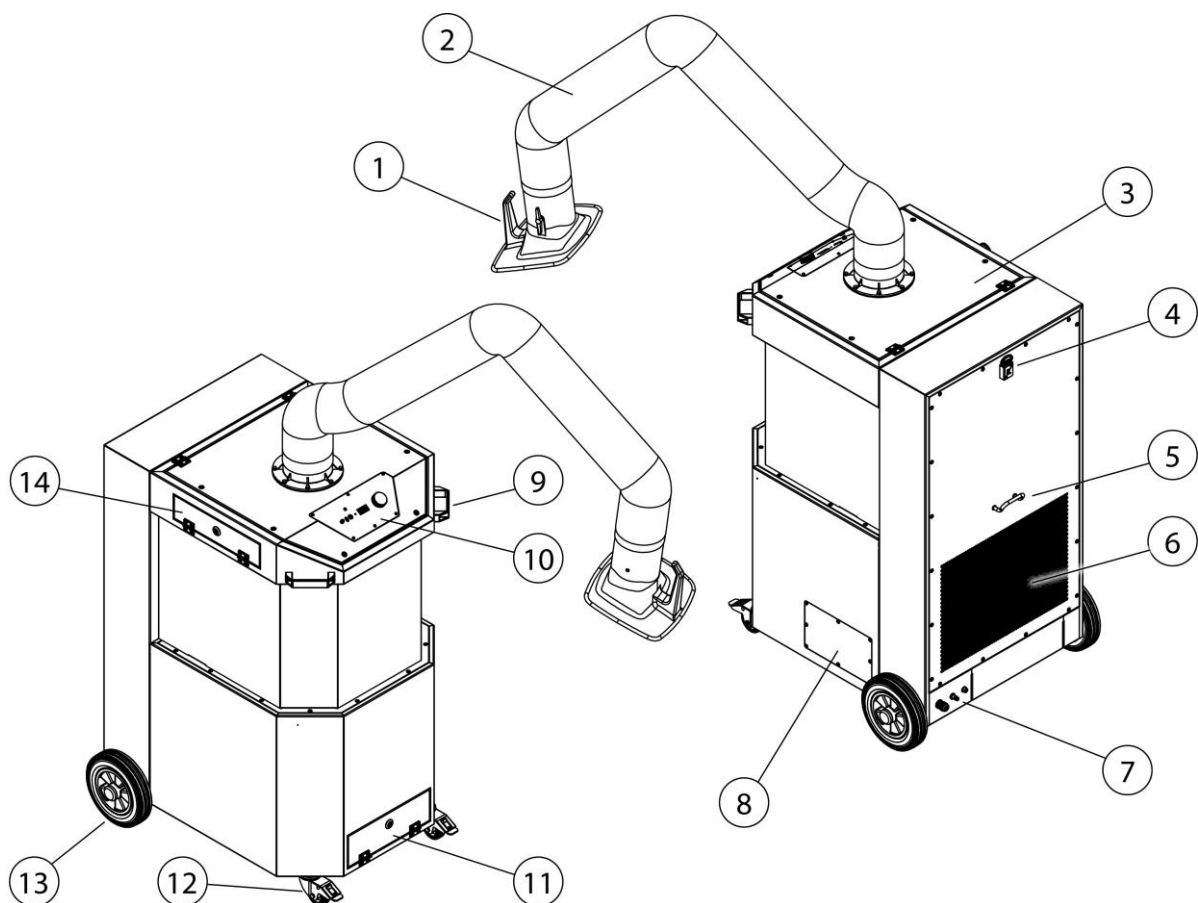

Fig. 1: Functional description

Item	Description	Item	Description
1	Extraction hood	8	Maintenance cover, control box
2	Extraction arm/support frame	9	Push handle
3	Cover plate	10	Operating control
4	Square socket wrench holder	11	Maintenance cover, dust collection container
5	Cable holder	12	Castor, lockable
6	Clean air outlet	13	Rear wheel
7	Connection panel	14	Maintenance cover, pre-filter

Tab. 1: Functional description – Positions on the product

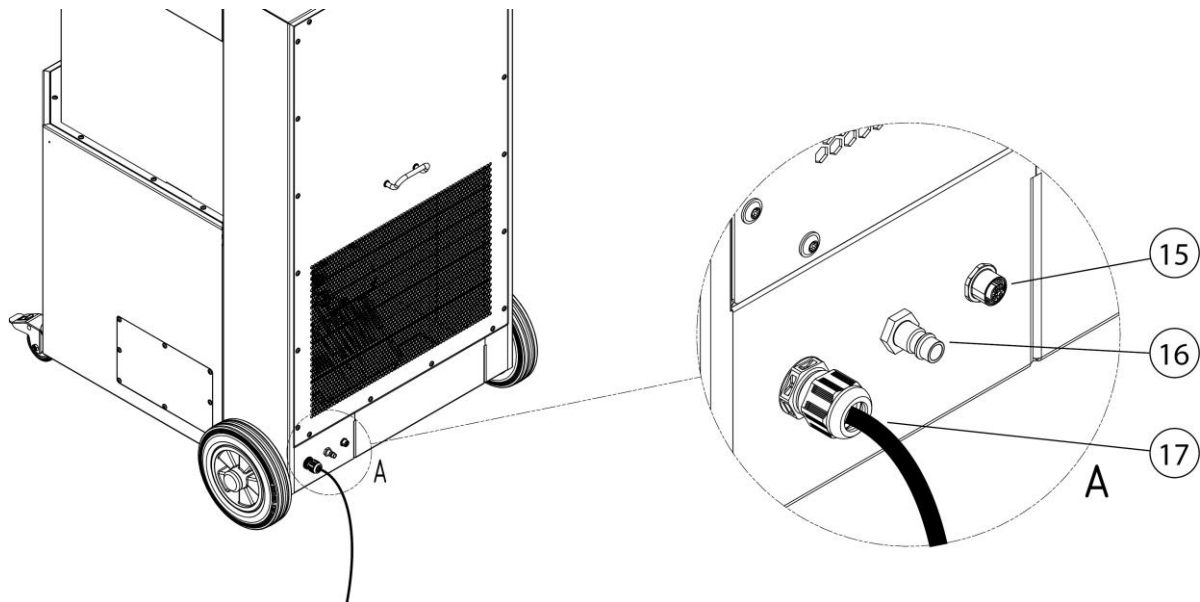

Fig. 2: Functional description – Connection panel

Item	Description	Item	Description
15	M12 connection socket for external on/off	17	Mains supply connection cable
16	Compressed air connection		

Tab. 2: Functional description – Connection panel

3.2 Distinguishing feature – W3 certified

The product is manufactured in two versions:

- **Version – non W3 certified**
- **Version – W3 certified**

Attention

Only products labelled with the W3 sticker have been tested and certified accordingly.

See also chapter technical data: Welding fume class and test standard.

W3-tested:

The product has been tested by the IFA (Institute for Occupational Safety and Health of the German Social Accident Insurance Institutions). It fulfils the requirements of welding fume separation class W3 and conforms to EN ISO 21904-1.

The tested products are labelled with the DGUV test mark and a W3-tested (marking of the welding fume separation class) in the form of a sticker.

Labelling on the product	Meaning/explanation	Reference logo
W3 sticker	Type "W3 certified" according to test standard – see chapter "Technical data"	

Tab. 3: W3 label

3.3 Intended use

This product is designed to extract and filter welding fumes produced during the welding of metallic materials at the point of origin.

This product must only be used for processes in which no incandescent sparks or flammable particles are drawn in.

Dimensions and further product details that must be observed can be found in the technical data.

NOTE



Only products labelled with the W3 sticker have been tested and certified accordingly. See also chapter Technical data: Welding fume class and test standard.

NOTE

When welding alloyed or high-alloy steels with filler metals above 5% chromium/nickel, carcinogenic CMR substances (carcinogenic, mutagenic, reprotoxic) are released. In accordance with official regulations, only tested and approved products may be operated in Germany to extract these harmful smoke particles using the so-called recirculation method.

Only products that meet the requirements of welding fume separation class W3/IFA certified may be operated for the aforementioned welding processes using the recirculation method.

When extracting welding fumes with carcinogenic components (e.g. chromates, nickel oxides, etc.), the requirements of TRGS 560 (technical rules for HAZMAT) and TRGS 528 (welding work) must be obeyed.

NOTE

The information in the "Technical data" chapter must be observed and strictly adhered to.

Intended use also includes observation of the instructions and information on

- safety
- operation and control
- maintenance and servicing

contained in this manual.

Any other use or use going beyond this is considered improper use. The company operating the product is solely responsible for any damage resulting from it. This also applies to unauthorised modifications to the product.

3.4 Ambient conditions

Operation or storage of the device outside the specified area is deemed unintended use and may impair the function, the extraction capacity and

the protective effect in accordance with DIN EN ISO 21904. The manufacturer is not liable for any resulting damage.

General:

- Ambient air free from dust, acids, corrosive gases or other aggressive substances.
- Height above sea level: up to 1000 m [3281 ft].
- For accordingly released products only: Indoor or outdoor operation permitted.

Temperature range of the ambient air:

Operating mode	Operation	Transport/ storage
Indoor (Indoor area)	+5 °C to 40 °C [+41 °F to +104 °F]	-20 °C to +50 °C [-4 °F to +122 °F]
Outdoor (For approved products only)	-10 °C to 40 °C [+14 °F to +104 °F]	-20 °C to +50 °C [-4 °F to +122 °F]

Table 4: Temperature range of the ambient air

Relative humidity (non-condensing unless approved otherwise):

- **Indoor:** up to 50% at +40 °C [+104 °F], up to 90% at +20 °C [+68 °F]
- **Outdoor:** up to 100%, including temporary condensation due to weather conditions

3.5 General requirements in accordance with DIN EN ISO 21904

NOTE

Connection of ducting systems, extraction arms and hoses.

Ducting systems, extraction arms and hoses connected to the product can lead to a pressure drop and must be taken into account by the system designer or user.

The connected components must be suitable for the product and ensure the required minimum volume flow (extraction capacity).

A possible design of the ducting can be requested from the manufacturer.

The connected components must be checked regularly for proper seating, leaks and blockages.

The required extraction capacity must be checked at the central extraction element.

NOTE

Returning the air to the workplace atmosphere

In some Federal States, recirculation of air into the workplace atmosphere is not recommended or is prohibited. It may be necessary to conduct the exhaust air to the outside via a duct.

3.6 Reasonably foreseeable misuse

No reasonable, foreseeable misuse is possible that could lead to dangerous situations with personal injury when working with the product whilst adhering to its intended use.

The operation of the product in industrial areas that do not comply with the requirements for explosion protection is not permissible.

Furthermore, the operation is prohibited for:

1. Processes that are not in the intended use list and in which the extracted air is:
 - is mixed with sparks, e.g. from grinding processes, which due to their size and quantity might lead to damage to the filter media or even to a fire;

- mixed with liquids and the resulting contamination of the air flow with vapours containing aerosols and oils;
 - mixed with highly flammable, combustible dust and/or with substances that can form explosive mixtures or atmospheres;
 - is mixed with other aggressive or abrasive dust that could damage the product and the filter elements employed;
 - is mixed with organic, toxic substances or a proportion of substances that are released when cutting the material.
2. Outdoor locations where the product is exposed to weather conditions because the product must only be installed in closed buildings. If there is an outdoor variant of the product available, this may be installed outside. Please note that additional accessories may be required for the outdoor installation.

3.7 Markings and signs on the product

Various markings and signs are affixed to the product. If these are damaged or removed, please replace them immediately with new ones in the same location.

The operating company is obliged to post further markings and signs on the product and the surrounding area if necessary.

Such notes and signs might be related, for example, to the requirement for wearing personal protective equipment.

In the country of use, additional required safety instructions and pictograms can be provided by the manufacturer in accordance with applicable law.

3.8 Residual Risk

Even when all safety rules are observed, when operating the product a residual risk remains, as described below.

All persons working on and with the product must be aware of these residual risks and follow the instructions that prevent these residual risks from causing accidents or damages.

⚠ WARNING

Danger of serious injury to the lungs and respiratory tract – always wear respiratory protection, Class FFP2 or higher.

Skin contact with welding fume particles may cause skin irritation in sensitive persons – wear protective clothing.

Before starting the welding process, ensure that the product is properly adjusted and in operation. The filter elements must be complete and in undamaged condition.

The connected detection element must reliably detect the welding fumes. For the correct positioning, refer to the documentation of the detection element.

When changing the filter inserts, skin contact with the separated dust particles may occur and parts of the dust particles may also be stirred up by the work. Respiratory protection and protective clothing must be worn.

Embers in the filter elements may cause smouldering fires – switch off the product, close the damper flap in the collection element if fitted and let the device cool down in a controlled manner.

⚠ WARNING

When extracting welding fume particles from laser welding processes, the collected dust may become more reactive, depending on the material, process parameters and operating conditions.

Under unfavourable conditions, this can lead to the heating of dust deposits and, in isolated cases, to smouldering processes in the filter or dust collection container.

This behaviour is highly dependent on the specific application (e.g. material, coatings, contaminants such as oil or grease) and does not occur in all applications.

To minimise potential risks, the following measures in particular must be observed:

- Regular inspection and emptying of the dust collection container
- Adherence to or adjustment of maintenance intervals
- Do not mix different types of dust
- Take process conditions and material influences into account

4 Transport and Storage

4.1 Transport

⚠ DANGER

Life-threatening crushing possible when loading and transporting the product!

Improper lifting and transporting may cause the pallet (if present) to tilt and fall!

- Never stand under suspended loads.
- Observe the permissible loads of the transport and lifting aids.
- Observe the applicable accident prevention and occupational safety regulations.

For transporting products with a pallet, use a suitable pallet truck or forklift. The weight of the product can be found on the name plate.

4.2 Storage

The product must be stored in its original packaging at an ambient temperature of 20 °C to +50 °C in a dry and clean place. The packaging must not be loaded by other objects.

The storage duration is not critical for all products.

4.3 Safety instructions for transporting the product

⚠ DANGER

- Potentially fatal crushing injuries when lifting and transporting the individual components of the product! Incorrect installation can cause components to fall down.
- Incorrect lifting and transport can cause the components of the product to tip over and fall down.
- The components of the product may only be lifted and transported with suitable lifting gear.
- Never stand under suspended loads or under improperly installed components.
- Lift and transport the individual components of the product with a single forklift only. The permissible load of the forklift must not be exceeded.
- Use suitable standard-compliant climbing aids and ensure that you are standing securely.
- Observe the applicable accident prevention and occupational safety regulations.
- Follow the instructions and regulations of the carrier.

The following safety instructions must be observed when transporting the product with a crane:

- Check that lifting gear is fixed firmly at the attachment points and on the crane hook.
- Attach the transport ropes to the crane hook in such a way that, when taut, they do not touch the machine parts lying above the attachment points.
- Use a loading harness if necessary.
- Adjust the lengths of the suspension cables so that the components of the product hang horizontally. Hook the suspension cables with shackles into all eyebolts/crane lugs. The angle of the suspension cables to the vertical must not exceed 30° and the eyebolts/crane lugs must not be loaded laterally. The eyebolts/crane lugs must not be deformed and should not be subsequently colour-coded (especially red) due to the risk of confusion.

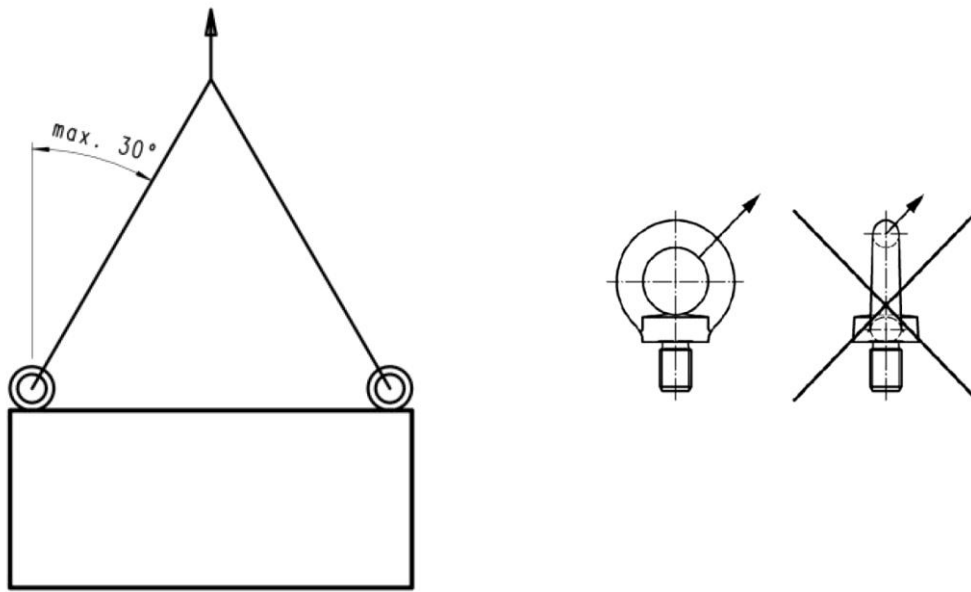

Fig. 3: Information on lifting procedure

- When choosing the shackle, ensure that each individual shackle has sufficient load capacity.

Transport of product with a crane

If necessary, the product can be lifted with a crane; there is a crane lug inside the product.

To access the crane lug, the filter cassette must be removed from the product. To do so, please proceed as follows:

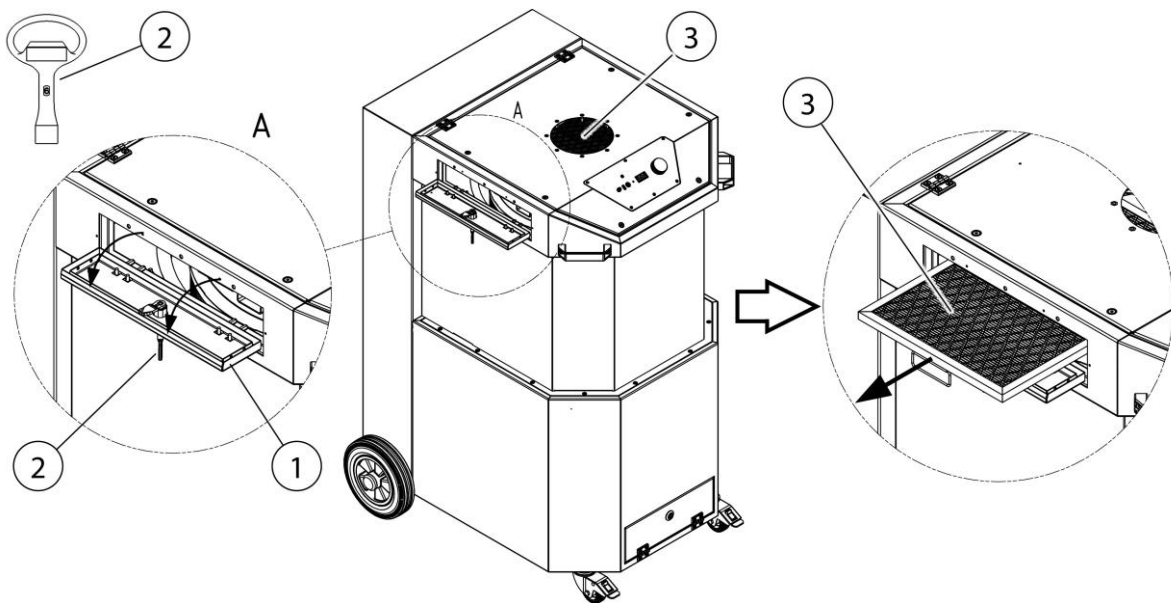

Fig. 4: Transporting the product

Item	Description	Item	Description
1	Maintenance cover	3	Filter cassette
2	Square socket wrench	4	Crane lug

Tab. 5: Transporting the product

1. Open the maintenance cover (Pos. 1) with the square socket wrench (Pos. 2) as shown in the illustration.
2. Pull the filter cassette (Pos. 3) out of the product to gain access to the crane lug (Pos. 4).

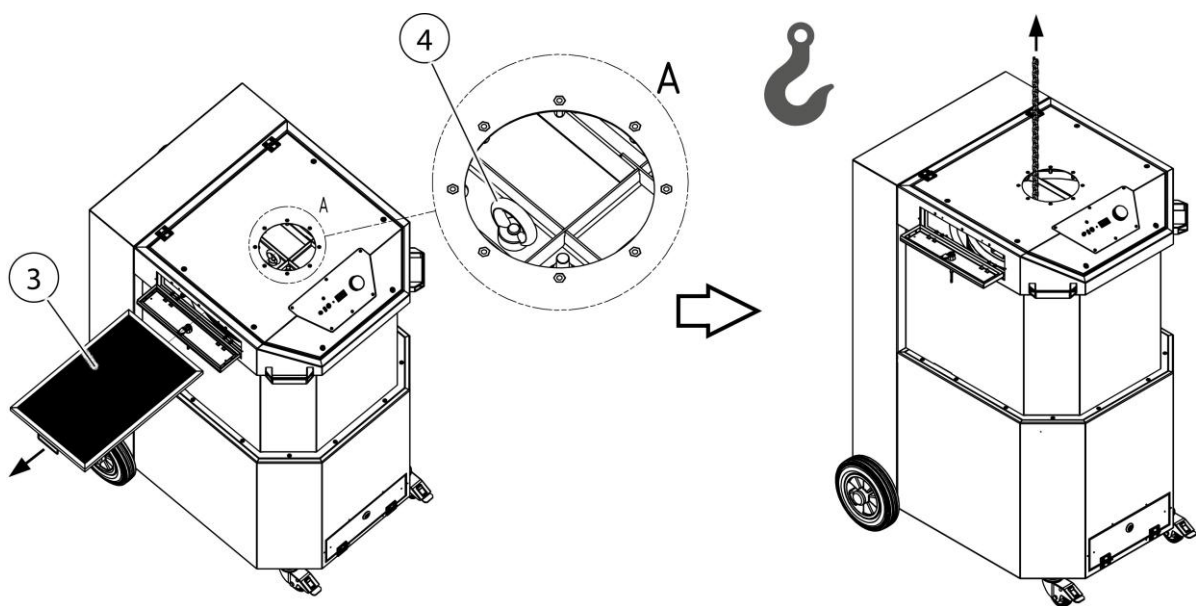

Fig. 5: Transporting the product

3. Attach a suitable lifting tool to the crane lug (Pos. 4) as shown in the illustration and lift the product.

5 Assembly

Instructions for safe installation of the product

NOTE

The operating company of the product may only assign specialists to carry out independent assembly.

- At least two people are needed to assemble the product.
 - It must be ensured that the installation location and point of use of the product provides sufficient load-bearing capacity and good stability.
-

⚠ DANGER

Falling or tipping parts may cause life-threatening injuries!

Tipping or falling loads lead to severe to fatal injuries.

- Observe the total weight, attachment points and centre of gravity of the load.
 - Observe the transport instructions and symbols on the transported goods.
-

⚠ WARNING

Incorrect connections may cause serious injuries!

Please note the necessary safeguards and only have the product connected by trained specialists.

NOTE

The operating company of the product may only commission persons to independently assemble the product if they are well-versed in this task.

Two people are needed to assemble the product.

Ensure that the welding current return line between the workpiece and the welding machine has a low resistance and that connections between the workpiece and the product are avoided so that the welding current cannot flow back to the welding machine via the product's protective conductor.

NOTE

If add-on products are also present, follow the appropriate manuals when assembling them.

Proceed to mount the product as follows:

1. Remove the tension straps and packaging material from the product.

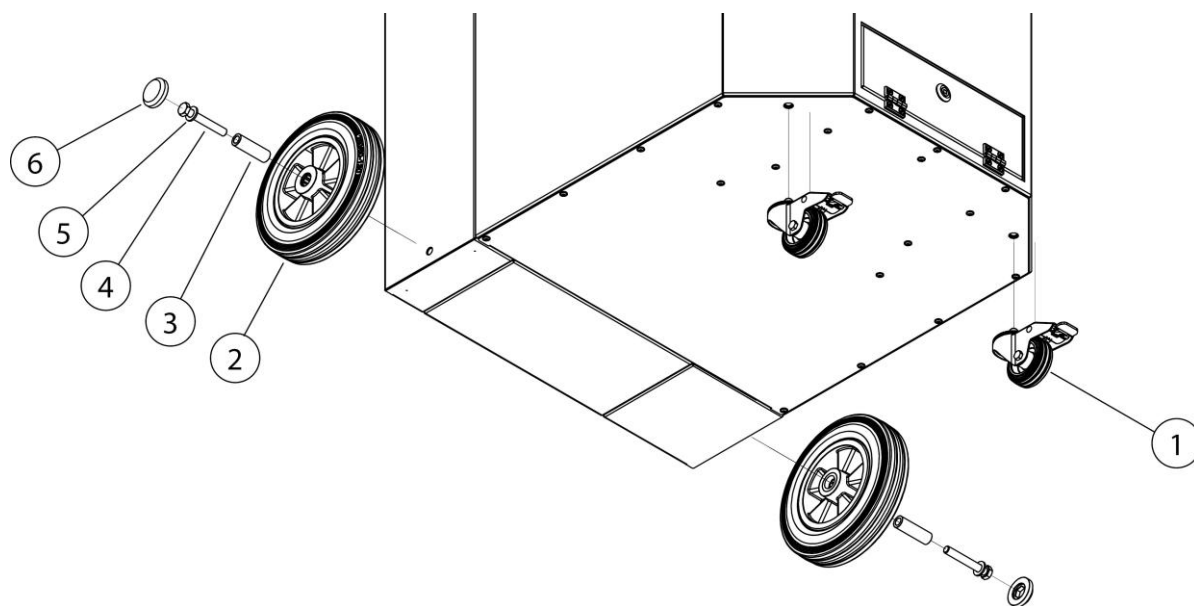

Fig. 6: Mounting - Wheel set

Item	Description	Item	Description
1	Swivel castor with brake	4	Hex bolt, M12
2	Rear wheel	5	Washer
3	Steel sleeve	6	Cover

Tab. 6: Positions on the product

2. Screw the two swivel castors with brake (Pos. 1) to the product as shown in the illustration.
3. Screw the two rear wheels (Pos. 2) to the product as shown in the illustration.

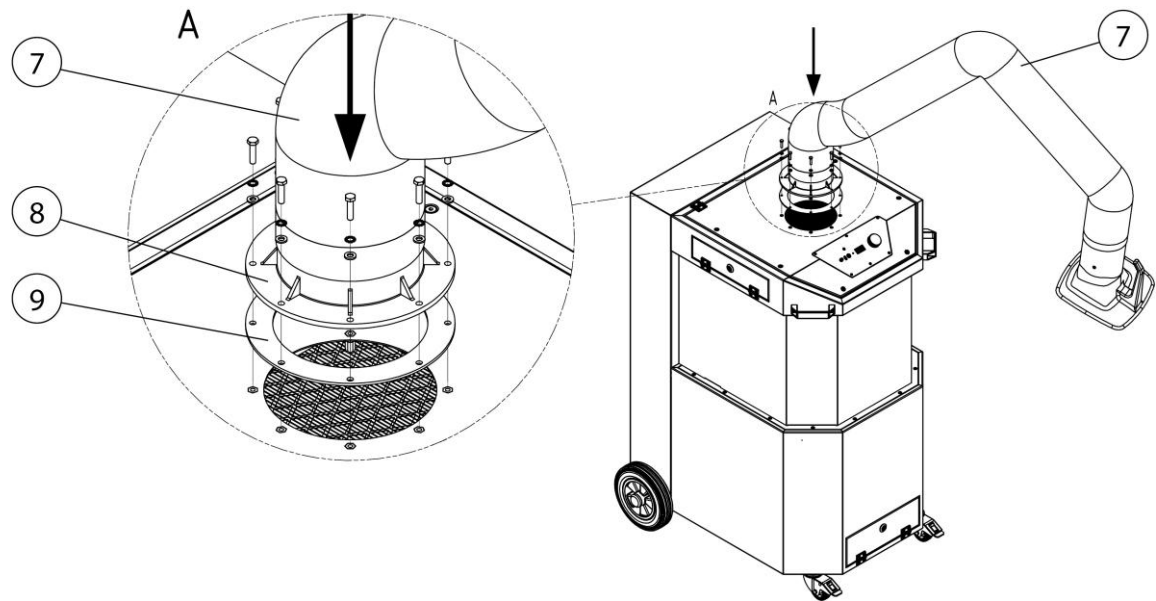

Fig. 7: Mounting – Extraction arm

Item	Description	Item	Description
7	Extraction arm	9	Flange seal
8	Slewing ring		

Tab. 7: Positions on the product

4. Screw the extraction arm (Pos. 7) to the product as shown in the illustration. Please also follow the steps in the enclosed instructions.

6 Use

Every person who deals with use, maintenance and repair of the product must have thoroughly read these operating instructions as well as the instructions for any attachment and accessory products and have understood them.

6.1 Qualification of the operating personnel

The operating company of the product may only commission persons to use the product independently if they are well-versed in this task.

Those familiar with this task includes those who have been instructed appropriately in the task and know the operating instructions as well as the operational issues in question.

The product should only be used by trained or instructed personnel. This is the only way to ensure safety and hazard awareness of all personnel during work.

6.2 Operating elements

Operating controls and connection options are located on the front side of the product:

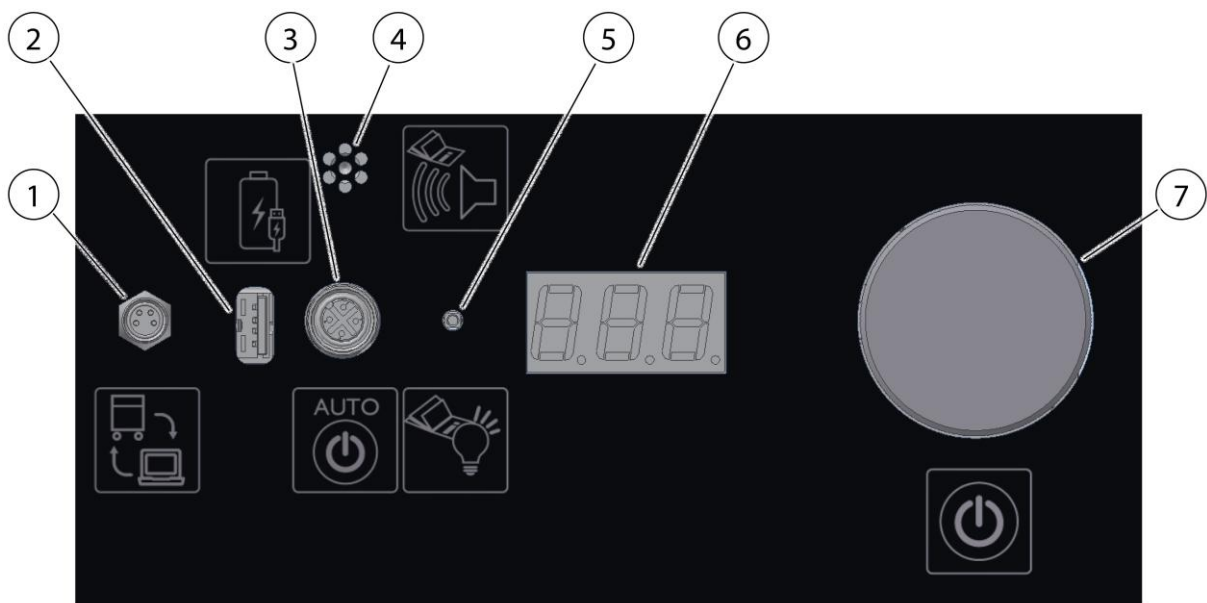



Fig. 8: Operating elements

Item	Description	Note
1	Communication interface	For service and optional extensions
2	USB charging socket	For charging commercially available USB devices
3	Connector socket for start-stop sensor	Optional automatic start/stop. See chapter "Spare parts and accessories"
4	Signal horn	See also chapter "Troubleshooting"
		
5	LED signal lamp	Indicates the current operating status
6	Digital LED display	Indicates settings, parameters, performance values, notes and faults
7	Rotary switch	Switches the product on or off
		Settings and queries can be carried out by turning and pressing the buttons.

Tab. 8: Operating elements

Alarm horn (Pos. 4)

NOTE



Reliable capture of welding fumes is only possible with sufficient extraction capacity. As the dust load on the filter increases, the flow resistance rises and the extraction capacity decreases.

As soon as it drops below a minimum value, the signal horn sounds.

If the integrated cleaning system is no longer sufficient, a filter change is required or the optional cleaning system must be started.

The same happens if the extraction capacity is reduced too much by closing the extraction hose.

A remedy is to check for blockages.

LED signal lamp (Pos. 5)

Signal colours are:

Green – indicates trouble-free operation

White – Menu – Queries and settings

Magenta – indicates one or more warnings (see “Troubleshooting” chapter)

Red – indicates a fault (see “Troubleshooting” chapter)

Digital LED display (Pos. 6)

The digital LED display indicates all settings, parameters and performance values, as well as possible faults and information.

The digital LED display shows [O F F] when switched off.

Rotary switch – Switching the product on/off (Pos. 7)

The rotary switch is used for all menu queries and settings.

- Turn = select, enter
- Press = confirm, acknowledge/switch product on/off
- Switching on the product: As soon as the rotary button (Pos. 7) is pressed briefly, the product starts. [O N]
- Switching off the product: Press the rotary switch (Pos. 7) again to switch the product off. [O F F]

6.2.1 Menu – Queries and settings

As soon as the rotary switch (Pos. 7) is pressed for approx. 3 seconds, the setting and query menu opens. The LED signal lamp (Pos. 5) lights up white.

In the menu, it is possible to switch between the menu items by turning the rotary switch (Pos. 7). Briefly press to display the value of the respective menu item.

Display	Description 1	Description 2	Setting value
DEL	Delay	Automatic start/stop run-on time	Yes
OPH	Operating hours	Operating hours	
HUS	Hours Until Service	Hours until maintenance	
dP	delta P	Differential pressure of the filter (kPA)	
dPA	Delta P Airflow	Pressure of the extraction volume measurement (kPA)	
tP	Total pressure	Extraction pipe vacuum (kPA)	
CLE	Cleaning processes	Number of cleaning processes	
US	1 = US, 0 = Metr.	Displayed units; Metric or US	
PFC	Pressure Filter Cleaning	Shows the filter pressure in Pa/kPa at which cleaning occurs automatically	
SEC	Service code	Service code	Yes

Tab. 9: Menu

NOTE

Pressure information below 1000 Pa is displayed in **Pa**.

Pressure information above 1000 Pa is displayed in **kPa**.

6.2.2 Activation codes

Advanced functions can be activated by entering activation codes.

Activation codes can be entered a maximum of 5 times in succession. A correct code is signalled by green flashing, an incorrect code by red flashing of the signal lamp (Pos. 5). If an incorrect code has been entered 5 times in succession, the code entry is blocked for 60 seconds. The menu item "SEC" cannot be activated then. Any further incorrect entry will then lock it again for 60 seconds.

6.2.3 Displaying the product ID

To query the three-digit product ID number, press and hold the rotary switch (Pos. 7) for more than 5 seconds.

The ID is required when, for example, the activation codes are to be entered.

If the rotary switch (Pos. 7) is pressed for longer than 10 seconds, the following appears on the digital LED display (Pos. 6): [SOFTWAREVERSION_DEVICETYPE]. For example, if [1_20] is displayed = Softwareversion 1 _ Devicetype 20

6.2.4 Automatic start/stop/external on/off

Automatic start/stop

As soon as the start/stop module (optional) is connected to the connection socket (Pos. 3), the product switches off and automatically switches to start/stop mode. In start/stop mode, the LED signal lamp (Pos. 5) flashes green.

When the start/stop module is activated by a welding process, the product starts. After the welding process is finished, the product switches off again after an adjustable run-on time. (preset run-on time 30 seconds)

During operation, the product can be switched off at any time by pressing the rotary switch (Pos. 7).

On/Off via extraction hood

There is a socket on the connecting piece of the extraction hood to switch the product on and off using a switch on the extraction hood. This signal has the same status as the on/off function of the rotary knob (Pos. 7).

On/Off via 4-pin connection socket

A potential-free contact can be connected to the 4-pin connector on the rear of the product. This connector is connected in parallel to the connector for connecting the extraction hood.

6.2.5 Warning – Insufficient extraction capacity

If the required extraction capacity is not achieved, a warning signal sounds after 5 minutes and [A 0 5] appears on the digital display (Pos 6). The LED signal light (Pos. 5) flashes in magenta during this message.

6.2.6 Cleaning the filter cartridge

A contaminated filter cartridge causes an increased differential pressure.

If a differential pressure of more than 1500 Pa occurs on the filter cartridge, cleaning of the filter cartridge is automatically triggered.

NOTE

For proper cleaning, the product must be connected to the compressed air network.

The compressed air supply is not monitored by the product.

6.3 Positioning the extraction hood

The extraction arm or extraction hood is designed in such a way that it can be adjusted and moved easily by hand. Once it has been positioned, the extraction hood maintains its set position of its own accord. Furthermore, both the extraction hood and the arm can be pivoted through 360° so that almost any position can be set. It is important that the extraction hood is always positioned properly in order to achieve adequate capture of the welding fumes. The correct position is shown on the following image.

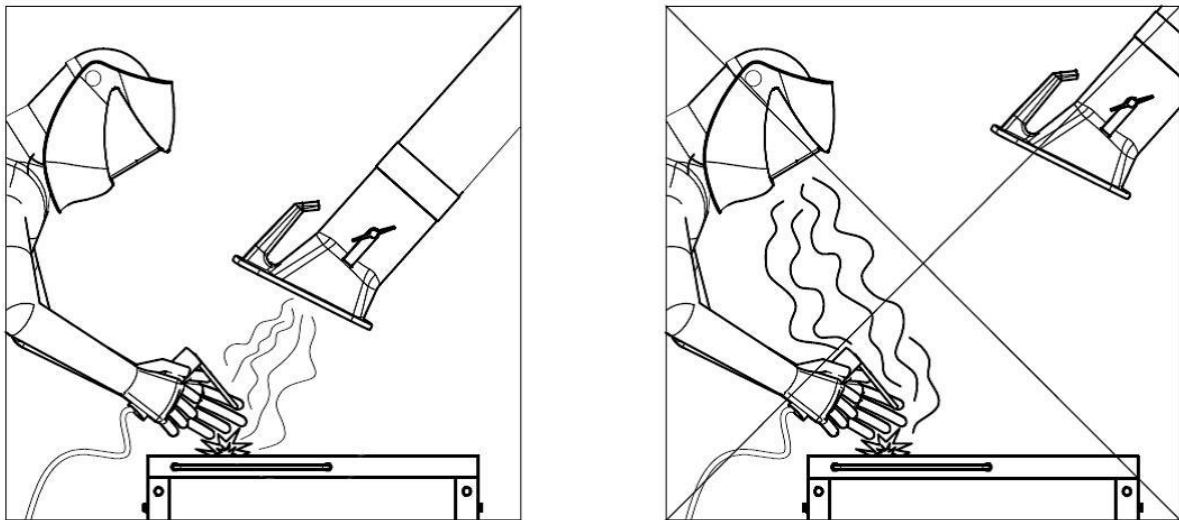

Fig. 9: Positioning the extraction hood

- Position the extraction arm so that the extraction hood is located approx. 25 cm diagonally above the weld.
- The extraction hood must be positioned so that it safely captures the welding fumes, taking into account the movement of welding fumes caused by the heat and the extraction range.
- Always move the extraction hood with respect to the weld position as you advance.

⚠ WARNING

An incorrectly positioned extraction hood or too low an extraction capacity do not ensure that air containing hazardous substances is captured adequately by the extraction hood. This means hazardous substances can enter the area where the operating personnel breathes and cause severe damage to health.

6.4 Commissioning

⚠ WARNING

Danger due to faulty product condition.

The product must be fully installed before commissioning begins. All doors must be closed and the necessary connections must have been made.

1. Connect the power supply connection cable of the product to the on-site power supply.
2. Switch on the product by pressing the On/Off switch.
3. The fan starts and the green signal light of the On/Off switch indicates trouble-free operation.

If there is a fault, please refer to the "Troubleshooting" chapter.

7 Maintenance

The instructions in this chapter are intended as minimum requirements. Depending on the operating conditions, further instructions may be required to keep the product in optimal condition.

The maintenance and repair work described in this chapter must only be performed by specially trained repair personnel of the operating company.

Spare parts used must comply with the manufacturer's specified technical requirements.

This is guaranteed if original spare parts are used.

The safe and environmentally friendly disposal of operating materials and replacement parts must be ensured.

The safety instructions in these operating instructions must be observed during maintenance work.

7.1 Care

The care of the product is essentially limited to cleaning all surfaces of the product and – if present – checking the filter inserts.

The warning notices listed in the chapter "Safety notes for maintenance and fault removal" must be observed.

NOTE

The product may not be cleaned with compressed air. This may result in dust and/or dirt particles getting into the ambient air.

Proper care helps to maintain the product in a continuous functional state.

For optimum care and cleaning of the powder-coated surfaces, the following must be observed:

- Thoroughly clean the product monthly or as needed.
- Clean the exterior areas of the product with a suitable industrial vacuum cleaner of dust classification H or with damp soft cloths/industrial cotton wool.
- For stubborn dirt, use commercially available household cleaners. Avoid vigorous rubbing.
- Do not use any abrasive agents that scratch.
- Do not use any acidic or strongly alkaline cleaning agents.
- Do not use organic solvents containing esters, ketones, alcohols, hydrocarbons or similar.

7.2 Maintenance

Regular inspection and servicing have a positive effect on the reliable functioning of the product and should be carried out at least once a year.

Except for the necessary filter replacements, the product operates maintenance-free.

Observe the warning notices for servicing and troubleshooting in the "Safety" chapter.

7.2.1 Special Notes on Laser Welding

NOTE

If the product is used to extract welding fumes from laser welding, more frequent maintenance is required. This applies in particular to regularly checking the dust collection container and emptying it in a timely manner.

Welding fume particles generated by this process may be more reactive and prone to spontaneous combustion. Cleaning and maintenance intervals must be shorter than those for conventional welding processes. Mixing of the dust with particles from other welding or machining processes must be avoided. The level of the dust collection container must be checked regularly and kept as low as possible.

7.2.2 Changing the filter – Safety instructions

The life of the filter inserts depends on the type and amount of deposited particles.

As the dust accumulation in the filter increases, its flow resistance increases and the extraction capacity of the product decreases.

Even with products that may have automatic filter cleaning, adhering deposits can reduce the extraction capacity.

A filter change is required.

⚠ WARNING

Health hazards caused by welding fume particles

Do not inhale welding dust / smoke! Serious injury to the lungs and respiratory tract is possible!

Sweat smoke contains substances that can cause cancer!

Skin contact with welding fume particles can cause skin irritation in sensitive individuals.

To avoid contact with and inhalation of these dust particles, wear disposable overalls, protective goggles, gloves and a suitable Class FFP2 respiratory protection filter mask in accordance with EN 149.

**⚠ WARNING**

Cleaning the filter inserts is not permitted. This inevitably leads to damage to the filter element, meaning the filter ceases to function and hazardous substances enter the air.

During the work described in the following section, pay particular attention to the seal on the main filter. Only an undamaged seal allows the product to achieve a high filter efficiency. Main filters with a damaged seal must therefore be replaced every time.

NOTE

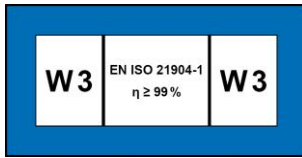

Products with W3 certification according to requirements for W3/IFA certified welding fume separation class. (See "Technical data" chapter)

The W3 approval becomes void if:

- The product is used other than as intended or is subject to constructive modifications.
 - Non-original spare parts, in accordance with the spare parts list, are used.
-

- Only original replacement filters, because they guarantee the necessary filter efficiency and are matched to the product and its performance characteristics.
- Switch the product off using the on/off switch.
- Secure the product against unintentional switching on. If available, pull out the mains plug or secure the main switch in the 0 position with a padlock.
- Disconnect the pressure supply, if present, and let the compressed air present in the product flow out via the condensate drain valve.

7.2.3 Changing filters

▲ WARNING

Work on the compressed air vessel and on the compressed air lines and components may only be performed by persons with expertise in pneumatics.

The pneumatic system must be isolated and depressurised prior to maintenance and repair work on the external compressed air supply, see also the Safety chapter

NOTE

Danger of material damage:

The extraction arm is mounted on the maintenance cover and is also lifted during the opening process. The extraction arm includes a cable with plug that must not be subjected to tension.

Disconnect the plug before raising the maintenance cover.

Removing the extraction arm beforehand is recommended to make changing the filter easier. (optional)

See operating instructions of the extraction arm for details

Perform the filter change as follows:

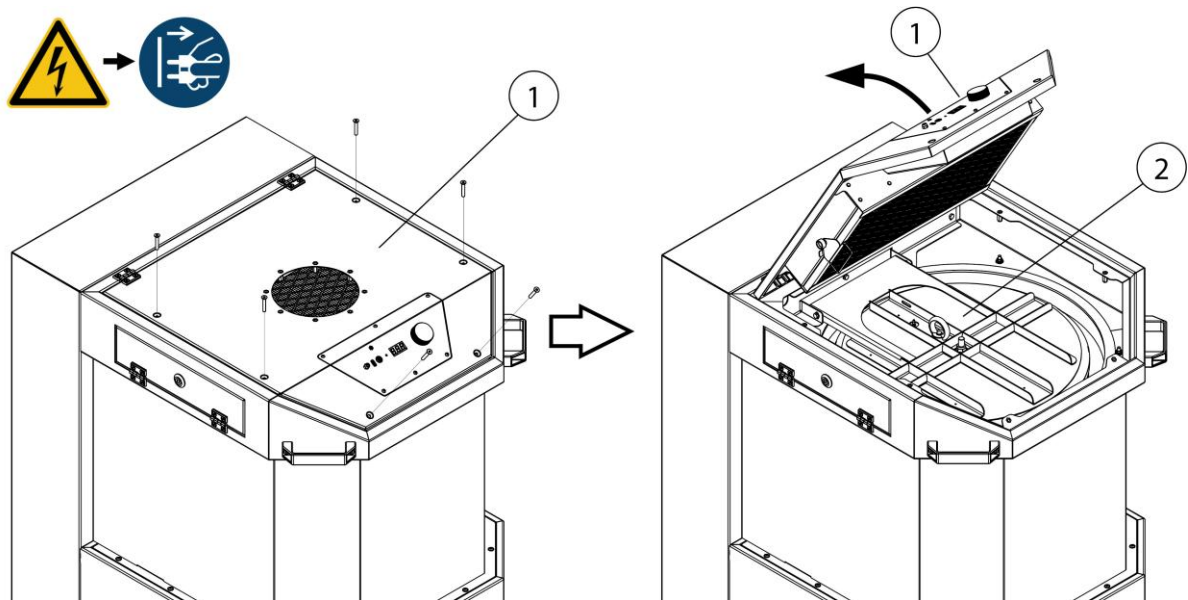

Fig. 10: Changing filters – Access to the filter cartridge

Pos.	Description	Pos.	Description
1	Cover plate	2	Filter cover

Table 10: Changing filters – Access to the filter cartridge

1. Provide a new filter cartridge.
2. Switch off the product at the rotary switch.
3. Disconnect the product from the power supply by unplugging.
4. Open the cover plate (Pos. 1) as shown in the illustration. To do this, remove the 6 screws using a suitable tool.

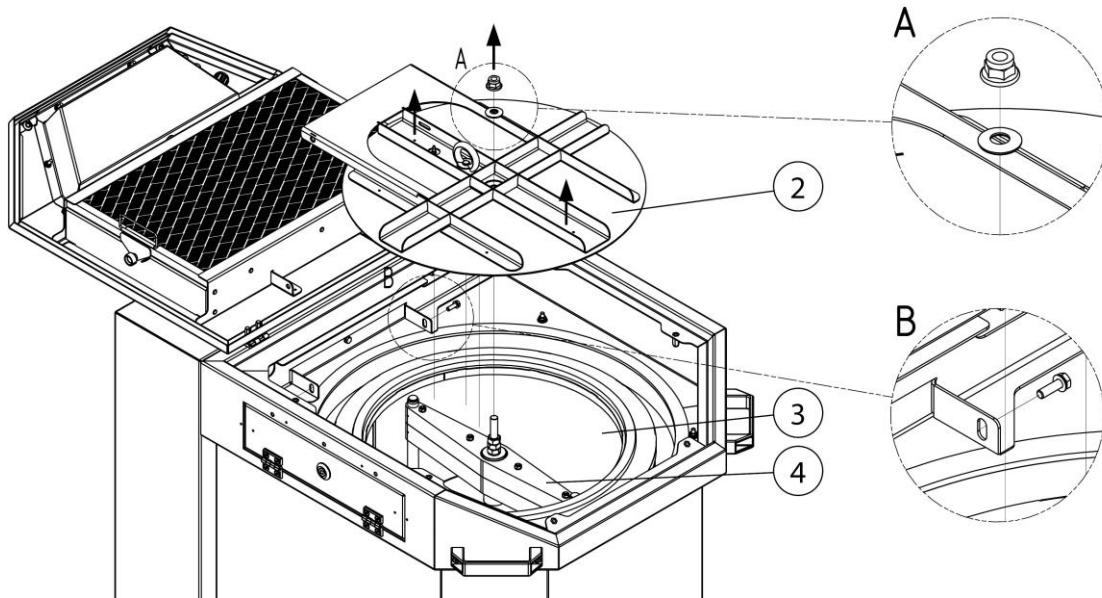

Fig. 11: Changing filters – Removing the filter cover

Pos.	Description	Pos.	Description
2	Filter cover	4	Rotation nozzle
3	Filter cartridge		

Table 11: Changing filters – Removing the filter cover

5. Remove the filter cover (Pos. 2) as shown in the illustration. To do this, remove the hexagon nut (A) and the two hex bolts (B).
6. Pull off the measuring hose on the filter cover (Pos. 2) and lift off the filter cover (Pos. 2) and set it aside.

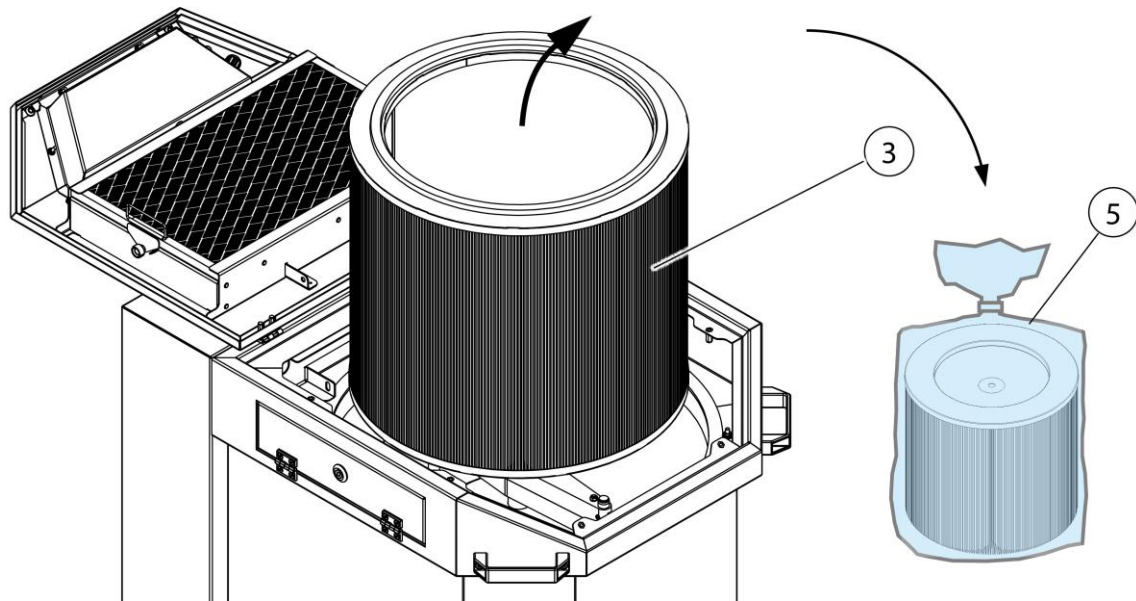

Fig. 12: Changing filters – Disposing of the filter cartridge

Pos.	Description	Pos.	Description
3	Filter cartridge	5	Disposal bag

Table 12: Changing filters – Disposing of the filter cartridge

7. Carefully remove the contaminated filter cartridge (Pos. 3) from the product without stirring up any dust and place it in the disposal bag (Pos. 5).
8. Seal the disposal bag (Pos. 5) airtight and dispose of it according to regulations.
9. The installation of the new filter cartridge (Pos. 3) is carried out in reverse order. Make sure the seals are seated correctly.
10. After installing the new filter cartridge, reconnect the product to the power supply and put it into operation. See also the Commissioning chapter.

7.2.4 Checking the compressed air container with compressed air safety valve

NOTE

The product has one or more compressed air containers with compressed air safety valve.

Products with compressed air container and safety valve must be serviced/checked according to current national regulations.

7.2.5 Checking the compressed air safety valve

The compressed air safety valve is located in the rear area of the product.

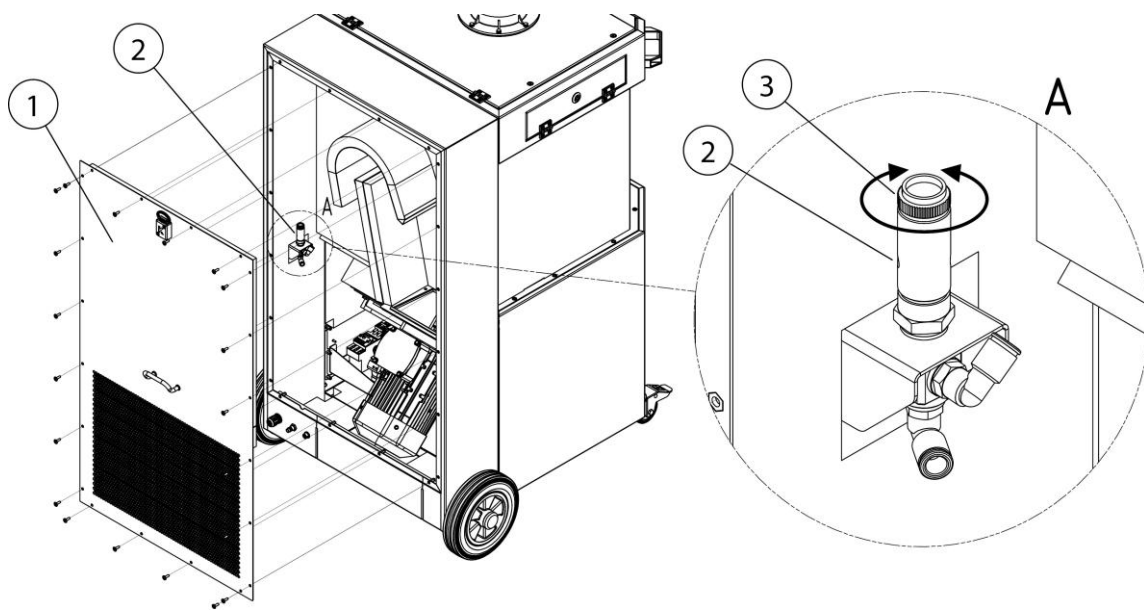

Fig. 13: Maintenance – Checking the compressed air safety valve

Item	Description	Item	Description
1	Maintenance cover	3	Knurled screw
2	Compressed air safety valve		

Tab. 13: Maintenance – Checking the compressed air safety valve

To gain access to the compressed air vessel/safety valve (Pos. 2), please proceed as follows.

1. Remove the maintenance cover (Pos. 1) on the rear of the product as shown in the illustration.
2. Loosen the knurled screw (Pos. 3) on the compressed air safety valve (Pos. 2) by turning it anti-clockwise and open it by approx. 3 - 4 turns until the exhaust air process starts. (audible discharge of compressed air)
3. Allow the compressed air safety valve to blow off briefly.
4. Screw in the knurled screw (Pos. 3) as far as it will go and hand-tighten it.
5. Close the maintenance cover (Pos. 1) and put the product back into operation. See chapter “Commissioning”

7.3 Troubleshooting

Fault	Cause	Note
Not all dust particles are collected	Distance between the extraction hood and the welding position too great	Move the extraction hood closer
	Clean air outlet obstructed	Keep clean air outlet free of obstruction
Signal horn sounds, the green indicator lamp in the switch does not light up	Extraction capacity too low, damper flap in the extraction hood is closed	Fully open the damper flap in the extraction hood
		
Extraction capacity too low/non-existent	Filter inserts saturated	Replace filter inserts
Dust particles escape on the clean air side	Filter inserts damaged	Replace filter inserts
Motor protection switch triggers	Motor blocked	Have this checked by a qualified electrician
Product will not start up	No mains voltage	Have this checked by a qualified electrician
	Start/stop sensor (optional fitting) connected, but no current detected Welding process not yet started	Start welding process
	Phase sequence error/missing phase. The fan is not rotating.	Changeover of two phases in the CEE plug by an electrician

Tab. 14: Troubleshooting

7.4 Troubleshooting - Error Codes

Error Code	Possible Cause	Note/ Fix
F1-F89	Error code from frequency converter	Acknowledging the error by pressing the rotary knob

F90	No communication to the frequency converter	De-energize the product for 10 seconds.
F91	Contactors feedback incorrect	Contactors defective – replace contactors
F92	Motor circuit breaker tripped due to overcurrent	Check if the engine is turning freely
	Power supply phase is missing	Have the power supply checked by a qualified electrician.
	Defective engine	Press the reset button on the motor circuit breaker
F93	Differential pressure on the filter too high, filter elements dirty	Changing the filter
	No compressed air connected – filter cleaning without function	Testing and manufacturing compressed air supply
F94	Control errors	De-energize the product for 10 seconds
F95	Compressed air supply not available	Establishing compressed air supply
F96	Rotation field of the supply line phases incorrect	Creating a right-hand rotation field
	Phase Missing	Check the electrical supply

Tab. 15: Troubleshooting – Error Codes

Note

If the fault cannot be rectified by the customer, the manufacturer's service must be contacted.

7.5 Troubleshooting Warnings

Warn-code	Possible Cause	Note/ Fix
SEr	Service Due	Perform service
A02	Differential pressure at the filter too high No compressed air connected – device cannot clean	Connect compressed air and switch on the system If necessary, contact the service
A04	Sensor error volume flow measurement	Contact manufacturer service
A05	Extraction power not sufficient (IFA) – signal horn sounds Filter elements dirty	Establish compressed air supply and switch on the product Changing the filter

Tab. 16: Troubleshooting - Warnings

7.6 Emergency measures

In case of fire of the product or its detection elements, the following steps should be taken if necessary:

1. Disconnect the product from the mains! If present; pull out mains plug; set main switch to 0-position; disconnect supply fuses.
2. If present, disconnect the compressed air supply.
3. Fight fire with a commercially available dry powder extinguisher.
4. Notify local fire brigade if necessary.

⚠ WARNING

Do not open products with maintenance door. Flash flame formation!

In the event of a fire, do not touch the product under any circumstances without proper protective gloves. Risk of burns!

8 Disposal

▲ WARNING

Skin contact with welding fumes, etc. can cause skin irritation in susceptible individuals.

Disassembly work on the product may only be carried out by trained and authorised personnel while complying with the safety rules and the applicable accident prevention regulations.

Serious injury to the lungs and respiratory tract is possible!

In order to avoid contact with and inhalation of dust particles, use protective clothing, gloves and a blower respirator system.

The release of hazardous dust particles must be avoided during dismantling work so that persons in the vicinity are not harmed.

▲ CAUTION

All work on and with the product must comply with the legal obligations for waste avoidance and proper recycling/disposal.

8.1 Plastics

Plastics, if present, must be sorted as far as possible. Plastics must be disposed of in compliance with the legal requirements.

8.2 Metals

Metals, if present, must be separated and disposed of. Disposal must be carried out by an authorised company.

8.3 Filter elements

Filter elements, if present, must be disposed of in compliance with the legal requirements.

9 Annex

9.1 EU Declaration of Conformity

Designation: Welding smoke filter unit
 Series: MaxiFil Clean
 Type: 67250, 67251, 67252 (possibly different article numbers for other product variants)
 Machine ID: (serial number) see the name plate on the product
 This product is developed, designed and manufactured in accordance with EC directives
 2006/42/EC – Machinery Directive

The product continues to comply with the provisions of the
 2014/30/EU - EMC Directive
 2014/29/EU - Pressure Equipment Directive
 2011/65/EU - RoHS Directive

Company: At the sole responsibility of
 KEMPER GmbH
 Von-Siemens-Str. 20, D-48691 Vreden

The following harmonised standards are used:

- EN ISO 12100:2010 Safety of machinery - General principles for design
- EN ISO 13857:2019 Safety of machinery - Safety distances
- EN ISO 13854:2019 Safety of machinery - Minimum gaps
- EN ISO 21904-1:2020 Health and safety in welding and allied processes
- EN ISO 4414:2010 fluid power - General rules and safety requirements for systems and their components
- EN IEC 61000-6-2:2019 Electromagnetic compatibility (EMC) - Part 6-2: Generic standards - Immunity standard for industrial environments
- EN IEC 61000-6-4:2019 Electromagnetic compatibility (EMC) - Part 6-4: Generic standards - Emission standard for industrial environments
- EN 60204-1:2018 Safety of machinery - Electrical equipment of machines
- EN ISO 13849-1:2023 Safety of machinery - Safety-related parts of control systems

A complete list of standards, directives and specifications applied is available from the manufacturer. The operating manual belonging to the product is available.

Authorised representative:

Kemper GmbH, Von-Siemens-Str. 20, 48691 Vreden, Germany

The aforementioned person is authorised to compile the technical documentation in accordance with Annex VII of Directive 2006/42/EC.



Vreden, 28.05.2026

Place, date

B. KEMPER

CEO

Identification of the signatory

9.2 UKCA Declaration of Conformity

Designation: Welding fume filter unit
 Series: MaxiFil Clean
 Type: **67250, 67251, 67252** (possibly different article numbers for other product variants)
 Machine ID: (Serial number) see type plate on product
 This product is developed, designed and manufactured in accordance with the UKCA directives
 Supply of Machinery (safety) Regulations 2008

The product continues to comply with the provisions of the
 Electromagnetic Compatibility Regulations 2016
 Electrical Equipment (Safety) Regulations 2016
 Pressure Equipment Regulations 2016

At the sole responsibility of
 Company: **KEMPER GmbH**
 Von-Siemens-Str. 20, D-48691 Vreden

The following designated standards and technical specifications have been applied:

- BS EN ISO 12100:2010 Safety of machinery - General principles for design
- BS EN ISO 13857:2019 Safety of machinery - Safety distances
- BS EN ISO 13854:2019 Safety of machinery
- BS EN ISO 21904-1:2020 Health and safety in welding and allied processes
- BS EN ISO 4414:2010 fluid power - General rules and safety requirements for systems and their components
- BS EN IEC 61000-6-2:2019 Electromagnetic compatibility (EMC) - Part 6-2: Generic standards - Immunity standard for industrial environments
- BS EN IEC 61000-6-4:2019 Electromagnetic compatibility (EMC) - Part 6-4: Generic standards - Emission standard for industrial environments
- BS EN 60204-1:2018 Safety of machinery - Electrical equipment of machines
- BS EN ISO 13849-1:2023 Safety of machinery - Safety-related parts of control systems
- BS EN IEC 63000:2018 Technical documentation for the assessment of electrical and electronic products with respect to the restriction of hazardous substances

A complete list of standards, directives and specifications applied is available from the manufacturer. The operating manual belonging to the product is available.
 Additional information:

UK Authorised Representative:
 United Kingdom KEMPER (U.K.) Ltd.
 Venture Court, 2 Debdale Road, Wellingborough, Northamptonshire NN8 5AA
 The above-mentioned person is authorized to compile the technical documentation in Schedule 2 of the Supply of Machinery (Safety) Regulations 2008.

Vreden, 28.05.2026
 Place, date

 B. Kemper

CEO
 Identification of the signatory

9.3 Technical data

Designation	Type		
Filters	67250	67251	67252
Filter stages	2		
Filter method	Cleanable filter		
Cleaning method	Rotating nozzle		
Filter surface m ² [ft ²]	15 [161]		
Number of filter elements	1		
Total filter surface m ² [ft ²]	15 [161]		
Type of filter	Filter cartridge + aluminium mesh		
Filter material for main filter + pre-filter	ePTFE membrane + aluminium mesh		
Filter efficiency ≥ %	99.9		
Welding fumes class	W3		
IFA test standard	DIN EN ISO 21904-1+2		
Filter class/dust classification	M		
Basic data			
Maximum fan capacity m ³ /h [CFM]	4500 [2648]		
Extraction capacity m ³ /h [CFM]	1450 [853]		
Vacuum Pa [inch WC]	3300 [13]		
Minimum extraction capacity (triggering threshold for volume flow monitoring) m ³ /h [CFM]	750 [441]		
Motor power kW [hp]	2.2 [2.95]		
Power supply/rated current/ISO class	See name plate		
Protection type	IP21		
Permissible ambient temperature (operation) °C [°F]	+5 to +40 [+41 to +104]		
Duty cycle %	100		
Noise level dB(A)	73		
Compressed air supply bar [PSI]	5 – 6 [73 – 87]		
Compressed air consumption NI/min [CFM]	240 [8]		
Compressed air class	2:4:2 ISO 8573-1		

Dimensions of the basic product W x H x D	See Dimensions sheet
Basic product weight kg [lbs]	197 [435]
Additional information	
Fan type	Radial fan

Table 17: Technical data

9.4 Dimensions sheet

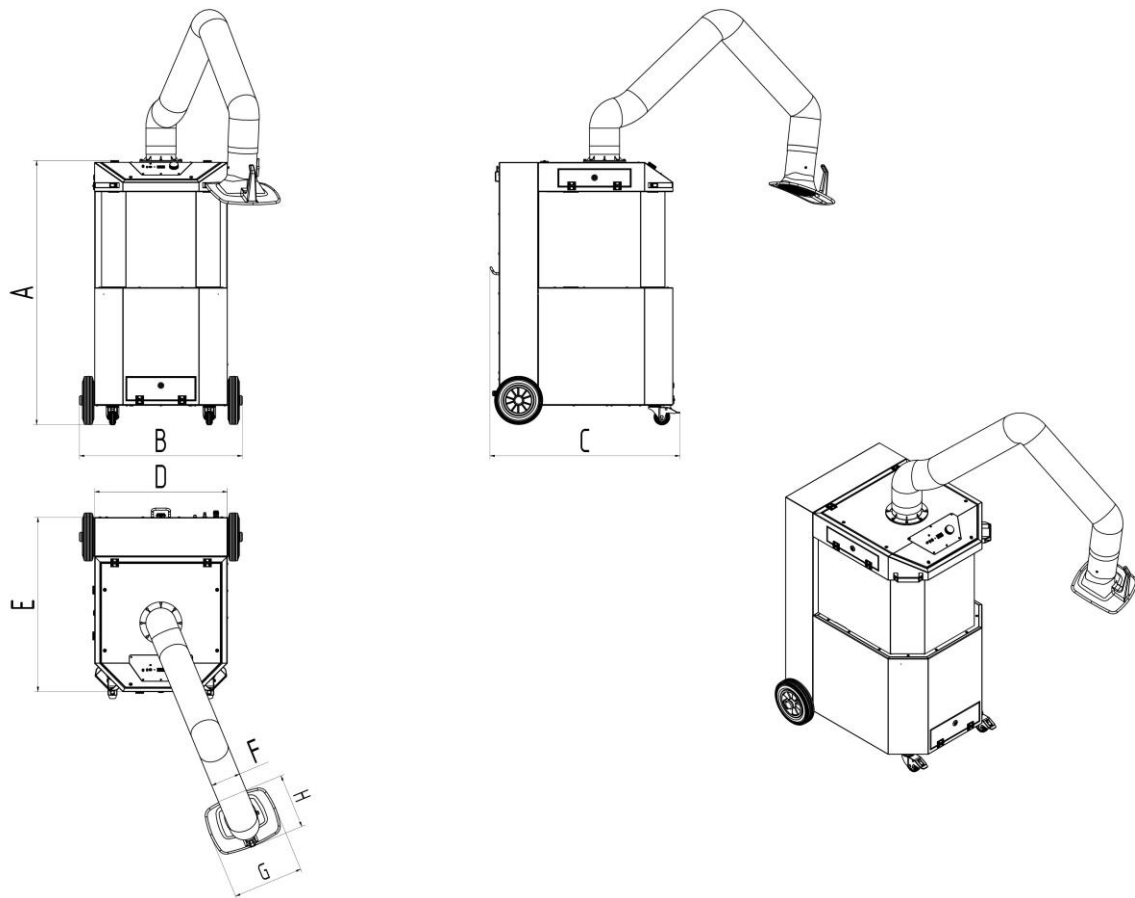

Fig. 14: Dimensions sheet

Symbol	Dimensions mm [in]	Symbol	Dimensions mm [in]
A	1350 [53.2]	E	890 [35.0]
B	834 [32.8]	F	150 [5.9]
C	973 [38.3]	G	360 [14.2]
D	680 [26.8]	H	295 [11.6]

Tab. 18: Dimensions table

9.5 Spare parts

Consec. No.	Description	Part no.
1	Main filter	1090469
2	Pre-filter insert, aluminium mesh	1090732
3	Dust collection container, set of 5	1191142
4	Wheel set	6430015

Table 19: Spare parts

9.6 Accessories

Consec. No.	Description	Part no.
1	Automatic start/stop sensor, 5 m connection cable and adapter for single-arm products	94102702
2	Exhaust set NW 250 mm	1350453

Table 20: Accessories

Deutschland (HQ)**KEMPER GmbH**

Von-Siemens-Str. 20
D-48691 Vreden
Tel. +49 2564 68-0
Fax +49 2564 68-120
mail@kemper.eu
www.kemper.eu

United Kingdom**KEMPER (U.K.) Ltd.**

Venture Court
2 Debdale Road
Wellingborough
Northamptonshire NN8 5AA
Tel. +44 1327 872 909
Fax +44 1327 872 181
mail@kemper.co.uk
www.kemper.co.uk

France**KEMPER sàrl**

7 Avenue de l'Europe
F-67300 Schiltigheim
Si vous appelez de France
Tél. +33 800 91 18 32
Fax +33 800 91 90 89
De Belgique ou de l'étranger
Tél. +492564 68-135
Fax +492564 68-40135
mail@kemper.fr
www.kemper.fr

China**KEMPER China**

Floor 2, Building 6
No. 500 Huapu Road
Shanghai 201799
P.R. of China
Tel. +86 (21) 5924-0978
Fax +86 1852-1069-401
info@kemper-china.com.cn
www.kemper.cn.com

Ceská Republika**KEMPER spol. s r.o.**

Pyšelská 393
CZ-257 21 Porčí nad Sázavou
Tel. +420 317 798-000
Fax +420 317 798-888
mail@kemper.cz
www.kemper.cz

United States**KEMPER Fume****Extraction Systems LLC**

31465 Stephenson Hwy
Madison Heights
MI, 48071 USA
ph+1 (312) 815 5656
info@kemper-na.com
kemper-na.com

Canada**KEMPER Fume****Extraction Systems**

1-2, 1249 Seagrave Road
Woodstock, ON, N4T 0A8,
Canada
ph+1 (312) 815 5656
info@kemper-na.com
kemper-na.com

Nederland**KEMPER B.V.**

Demmersweg 92
Begane grond
7556 BN Hengelo
Tel. +492564 68-137
Fax +492564 68-120
mail@kemper.eu
www.kemper.eu

España**KEMPER IBÉRICA, S.L.**

Avda Diagonal, 421 3º
E-08008 Barcelona
Tel. +34 902 109-454
Fax +34 902 109-456
mail@kemper.es
www.kemper.es

India**KEMPER India**

55, Ground Floor, MP Mall
MP Block, Pitam Pura
New Delhi -110034
Tel. +91.11.42651472
mail@kemper-india.com
www.kemper-india.com

Polska**Kemper Sp. z o.o.**

ul. Grzybowska 87
00-844 Warszawa
Tel. +48 22 5310 681
Faks +48 22 5310 682
info@kemper.pl
www.kemper.pl

